

End Mill Grinder

Operation Manual

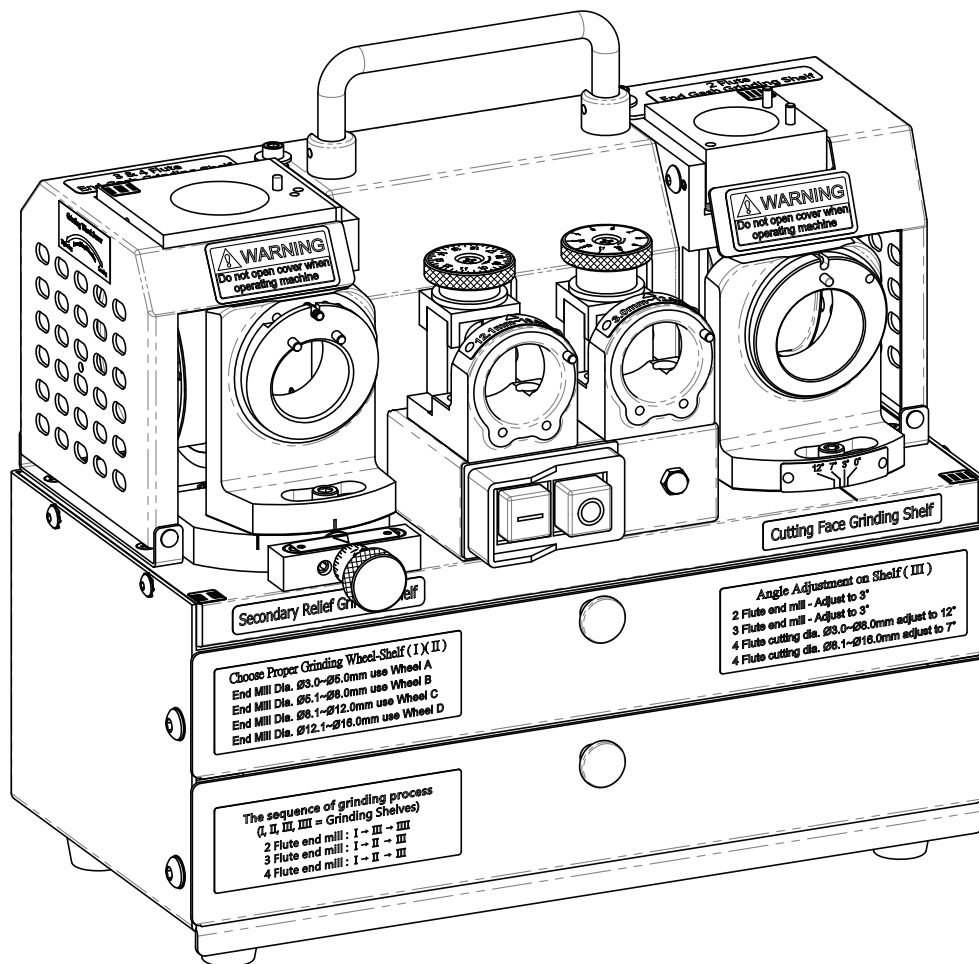

Model : GS-66

RECYCLING



Do not dispose of electrical appliances as unsorted municipal waste, use separate collection facilities.

Contact your local government for information regarding the collection systems available.

If electrical appliances are disposed of in landfills or dumps, hazardous substances can leak into the groundwater and get into the food chain, damaging your health and well-being.

When replacing old appliances with new ones, the retailer is legally obligated to take back your old appliance for disposal at least for free of charge.

Index

I.	Safety Instructions	2
II.	Intended Use	6
III.	Machine Installation Instruction	6
IV.	Machine Devices Introduction.....	7
V.	Dust Collection Adapter Assembly Steps	8
VI.	Choose of Grinding Wheel & Accessories & Collet	9
VII.	Chuck Set Assembly Steps	9
VIII.	The use of the Positioning Shelf.....	11
IX.	The use of the Cutting Face Adjustment Device	12
X.	2 Flute End Mill Grinding Preparations	13
XI.	2 Flute End Mill Grinding Process	14
XII.	3 Flute End Mill Grinding Preparations	15
XIII.	3 Flute End Mill Grinding Process	16
XIV.	4 Flute End Mill Grinding Preparations	17
XV.	4 Flute End Mill Grinding Process	18
XVI.	Machine Maintenance and Clean.....	19
XVII.	Troubleshooting	20

I. Safety Instructions

All personnel working with the machine must be properly trained in its operation, and must follow strictly on the operating instructions and procedures given in this and all associated manuals. The machine may only be operated by persons who are authorized and trained.

The user of the machine must not remove, modify or obscure in any way the content or the readability of any safety label placed on or inside the machine.

The sound pressure level of this machine is less 70dB(A) with uncertainty 3dB.

The vibration total value does not exceed 2.5 m/s².

WARNING

Read all safety warnings, instructions provided with this power tool. Failure to follow all instructions listed below may result in electric shock, fire and/or serious injury.

Save all warnings and instructions for future reference.

1. Work area safety

- **Keep work area clean and well lit.** *Cluttered or dark areas invite accidents.*
- **Do not operate power tools in explosive atmospheres, such as in the presence of flammable liquids, gases or dust.** *Power tools create sparks which may ignite the dust or fumes.*
- **Keep children and bystanders away while operating a power tool.** *Do not let persons, especially children, not involved in the work touch the tool or the extension cord and keep them away from the work area.*

2. Electrical safety

- **Power tool plugs must match the outlet. Never modify the plug in any way.** *Do not use any adapter plugs with earthed (grounded) power tools. Unmodified plugs and matching outlets will reduce risk of electric shock.*
- **Do not abuse the cord. Never use the cord for carrying, pulling or unplugging the power tool. Keep cord away from heat, oil, sharp edges or moving parts.** *Damaged or entangled cords increase the risk of electric shock.*
- **Use proper extension cord.** *Make sure your extension cord is in good condition. When using an extension cord, be sure to use one heavy enough to carry the current your product will draw. An undersized cord will cause a drop in line voltage resulting in loss of power and overheating.*

- **Do not expose power tools to rain or wet conditions.** *Water entering a power tool will increase the risk of electric shock.*
- **Avoid body contact with earthed or grounded surfaces, such as pipes, radiators, ranges and refrigerators.** *There is an increased risk of electric shock if your body is earthed or grounded.*

3. Personal safety

- **Stay alert, watch what you are doing and use common sense when operating a power tool. Do not use a power tool while you are tired or under the influence of drugs, alcohol or medication.** *A moment of inattention while operating power tools may result in serious personal injury.*
- **Use personal protective equipment. Always wear eye protection.** *Protective equipment such as a dust mask, protective glasses, non-skid safety shoes, hard hat or hearing protection used for appropriate conditions will reduce personal injuries.*
- **Keep guards in place, in working order.** *Safety guards must never be removed when the tool is being used.*
- **Prevent unintentional starting. Ensure the switch is in the off-position before connecting to power source and/or battery pack, picking up or carrying the tool.** *Carrying power tools with your finger on the switch or energising power tools that have the switch on invites accidents.*
- **Remove any adjusting key or wrench before turning the power tool on.** *A wrench or a key left attached to a rotating part of the power tool may result in personal injury.*
- **Do not overreach. Keep proper footing and balance at all times.** *This enables better control of the power tool in unexpected situations.*
- **Dress properly. Do not wear loose clothing, gloves, neckties or jewelry which may get caught in moving parts.** *Keep your hair, clothing, gloves or jewelry away from moving parts.*
- **If devices are provided for the connection of dust extraction and collection facilities, ensure these are connected and properly used.** *Use of dust collection can reduce dust-related hazards.*
- **Do not let familiarity gained from frequent use of tools allow you to become complacent and ignore tool safety principles.** *A careless action can cause severe injury within a fraction of a second.*
- **Use only designated clamps to hold workpiece.** *It's safer than using your hand and it frees both hands to operate tool.*

- **Never stand on tool.** *Serious injury could occur if the tool is tipped or if the cutting tool is unintentionally contacted.*
- **Never leave tool running unattended. Turn power off.** *Don't leave tool until it comes to a complete stop.*

4. Power tool use and care

- **Do not force the power tool. Use the correct power tool for your application.** *The correct power tool will do the job better and safer at the rate for which it was designed.*
- **Do not use the power tool if the switch does not turn it on and off.** *Any power tool that cannot be controlled with the switch is dangerous and must be repaired.*
- **Disconnect the plug from the power source and/or remove the battery pack, if detachable, from the power tool before making any adjustments, changing accessories, or storing power tools.** *Such preventive safety measures reduce the risk of starting the power tool accidentally.*
- **Store idle power tools out of the reach of children and do not allow persons unfamiliar with the power tool or these instructions to operate the power tool.** *Power tools are dangerous in the hands of untrained users.*
- **Maintain power tools and accessories. Check for alignment of moving parts, binding of moving parts, breakage of parts, mounting, guards, cord and any other condition that may affect the power tool's operation. If damaged, have the power tool repaired before use.** *Many accidents are caused by poorly maintained power tools.*
- **Keep cutting tools sharp and clean.** *Properly maintained cutting tools with sharp cutting edges are less likely to bind and are easier to control.*
- **Use the power tool, accessories and tool bits etc. in accordance with these instructions, taking into account the working conditions and the work to be performed.** *Use of the power tool for operations different from those intended could result in a hazardous situation.*
- **Keep handles and grasping surfaces dry, clean and free from oil and grease.** *Slippery handles and grasping surfaces do not allow for safe handling and control of the tool in unexpected situations.*
- **Do not use damaged grinding wheels.**
- **Use only grinding wheels and accessories that are recommended by the manufacturer.** *Use of unauthorized accessories may result in personal injury.*
- **The grinding wheel will not be dressed.**

- Please use the air spray gun and duster to clean all sharpened dusts from the machine after finishing the grinding job.
- **Direction of feed.** *Feed work into a blade or cutter against the direction of rotation of the blade or cutter only.*

5. Service

- **Have your power tool serviced by a qualified repair person using only identical replacement parts.** *This will ensure that the safety of the power tool is maintained.*

Explanation of Labels

	Indication of ground wiring
---	-----------------------------

II. Intended Use

This grinding machine is suitable for grinding and sharpening 2 flutes, 3 flutes and 4 flutes HSS / carbide end mill.

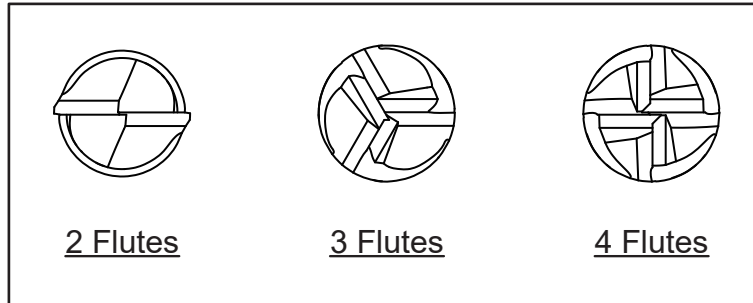

III. Machine Installation Instruction

1. Environmental Condition

- Place the machine on a “flat” and “stable” working table.
- Operate the machine in dry environment and away from liquid.
- Make sure power plug and power cord are installed in proper location.

2. Power Supply

Make sure the local power supply is matching with the voltage specification from the product label.

Please check the switch is in off position before plugging into socket outlet.

3. Motor Direction Test

- ① Plug the power cord into socket outlet.
- ② Check the grinding wheel protection cover is fastened by the screw.
- ③ Quickly switch on and off the machine, then check if the rotating direction of the right side grinding wheel is **counterclockwise**.
- ④ Switch on the machine again and check if any abnormal sound.

(The Machine is equipped with carbon brush DC motor. A slightly grinding sound is considered as normal condition.)

IV. Machine Devices Introduction

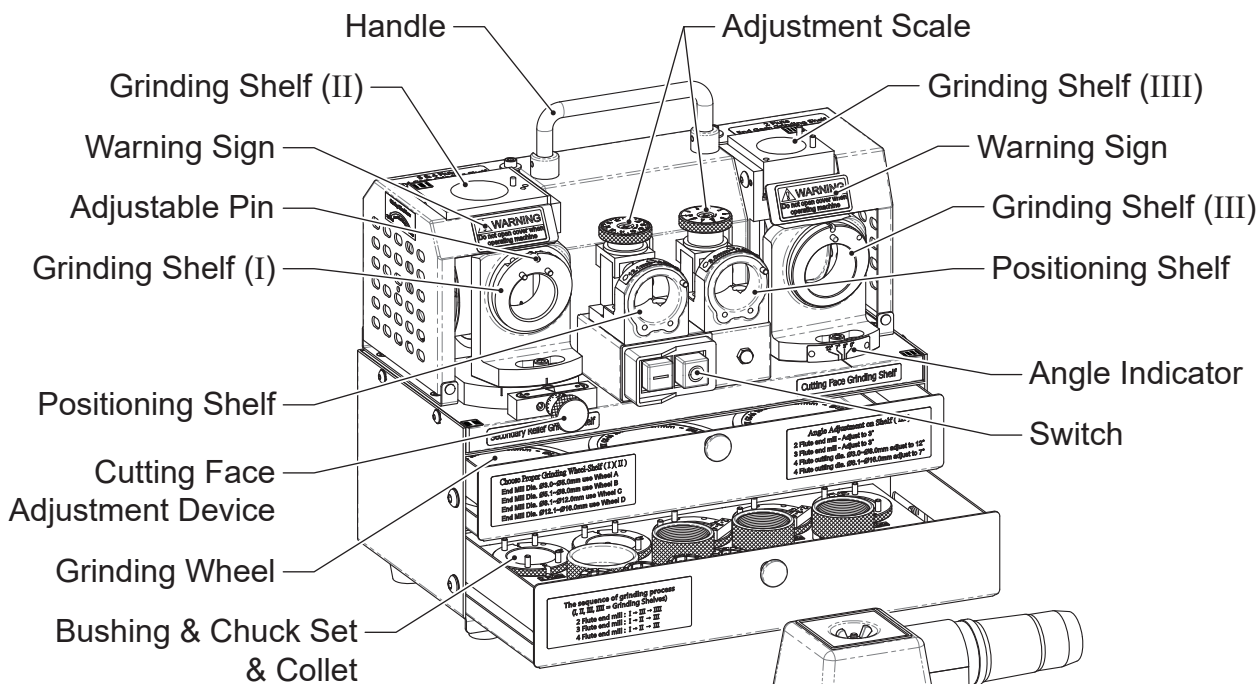

For End Mill diameter:
 $\Phi 3.0 \text{ mm} - \Phi 16.0 \text{ mm}$

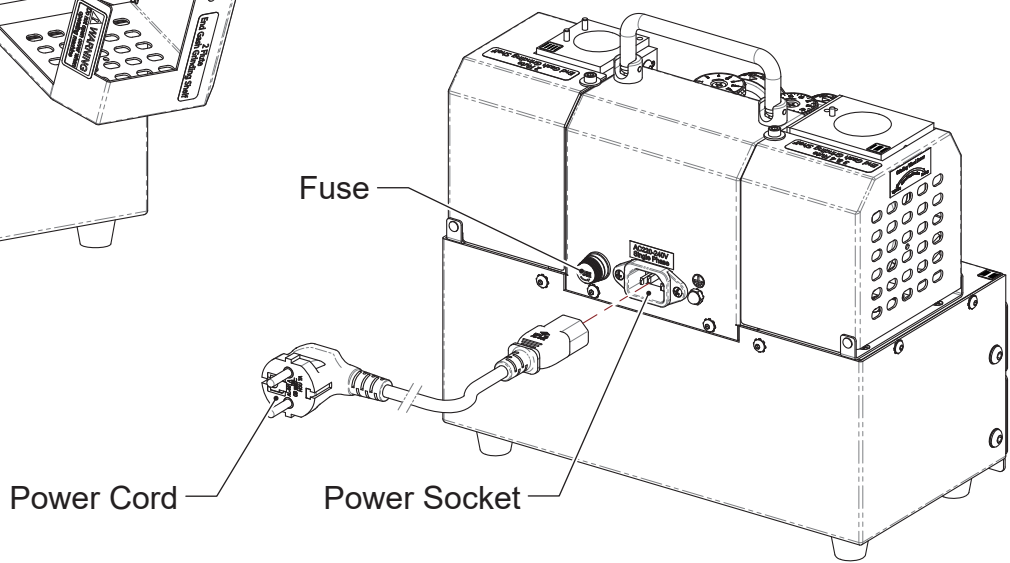
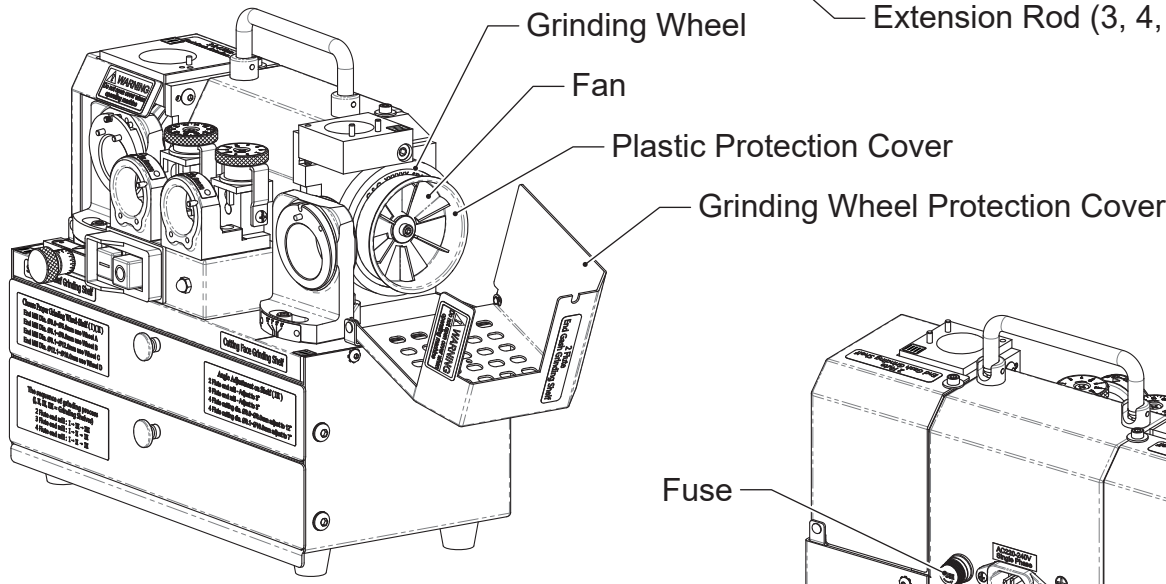
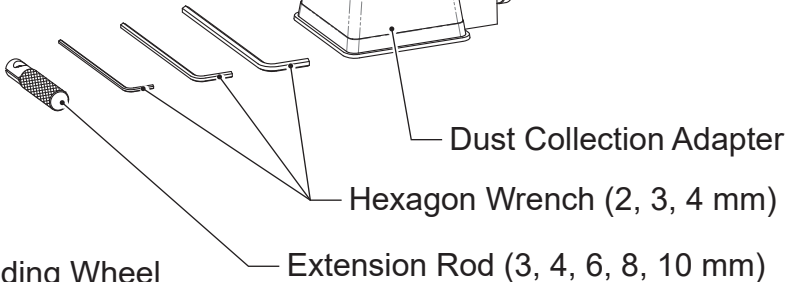

V. Dust Collection Adapter Assembly Steps

1. Thread the hex nut onto the suitable position of the threaded rod, align the end of the threaded rod containing the hex nut to the tapped hole of grinding wheel cover, and turn the threaded rod clockwise to thread the rod into the grinding wheel cover and tighten lightly. (Fig. 5-1)

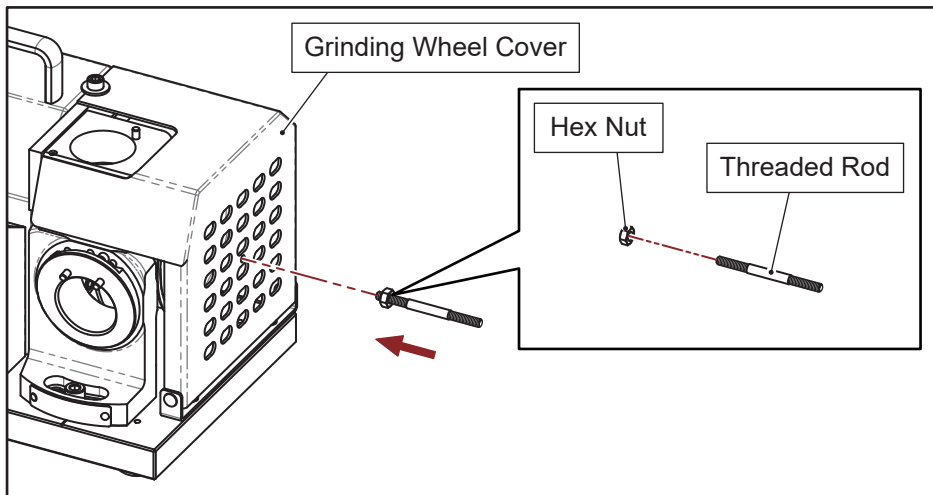

Fig. 5-1

2. Align the hole in the center of the dust collection adapter to threaded rod. Push the dust collection adapter to the end. (Fig. 5-2)
3. Assemble the washer and wing nut and tighten the wing nut to secure the dust collection adapter. (Fig. 5-3)

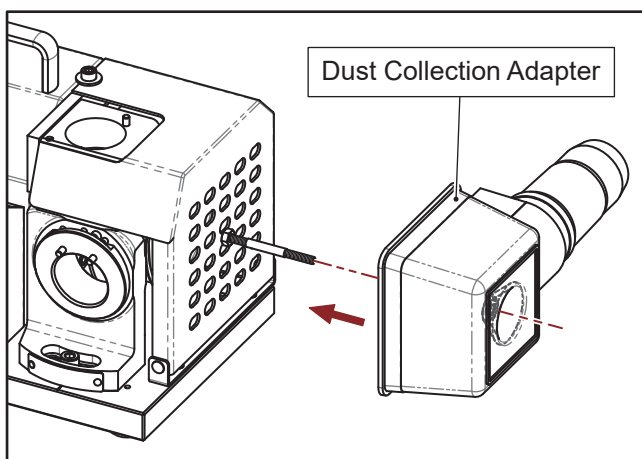

Fig. 5-2

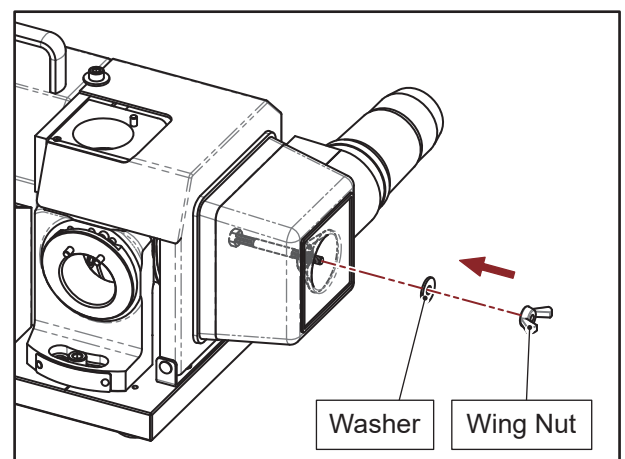

Fig. 5-3

VI. Choose of Grinding Wheel & Accessories & Collet

1. Please unplug the power cord before changing grinding wheel.
2. Choose the proper grinding wheel according to the material of end mill.
 - Carbide / Tungsten material end mill use SD grinding wheel (Standard).
 - HSS material end mill use CBN grinding wheel (Optional).
3. For grinding Shelf (I) and Shelf (II), there are four different sizes of grinding wheel. Choose the proper grinding wheel according to end mill's cutting diameter
 - Grinding Wheel A is for grinding the diameter from $\Phi 3.0$ mm - $\Phi 5.0$ mm.
 - Grinding Wheel B is for grinding the diameter from $\Phi 5.1$ mm - $\Phi 8.0$ mm.
 - Grinding Wheel C is for grinding the diameter from $\Phi 8.1$ mm - $\Phi 12.0$ mm.
 - Grinding Wheel D is for grinding the diameter from $\Phi 12.1$ mm - $\Phi 16.0$ mm.
4. Choose the proper bushing and chuck set according to the number of flute.
5. Choose the proper collet according to end mill's diameter.

VII. Chuck Set Assembly Steps

1. Make sure there are no dust or scraps inside the clamping nut, collet and collet holder.
2. Put the collet into collet holder by 45° angle. (Fig. 7-1)
3. Screw in a little bit by clamping nut, then insert end mill shank into the clamping nut until the end mill tip is about 5 mm out of the clamping nut (Fig. 7-2), slightly screw the chuck set to tighten the end mill a little bit.
 - ✘ Do not fully tighten the chuck set, make sure end mill can still be adjusted.

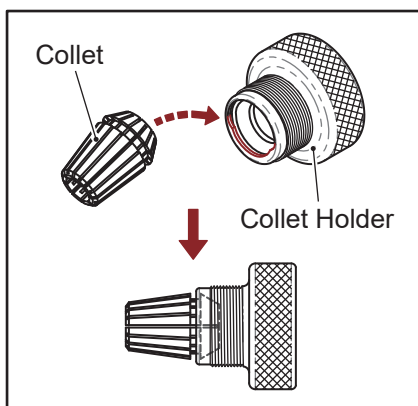

Fig. 7-1

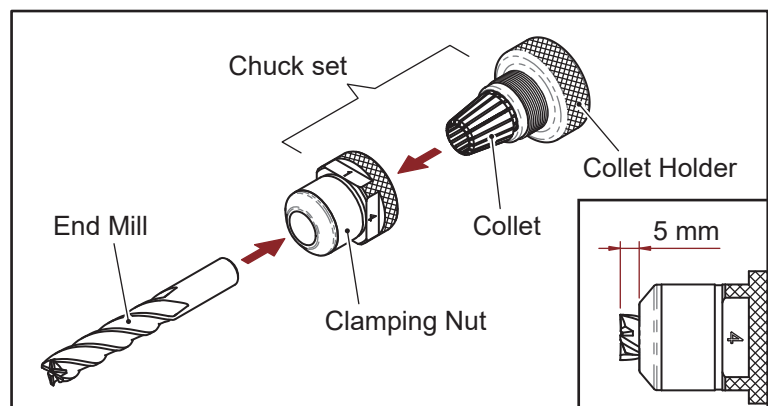

Fig. 7-2

(continued on next page)

(continued from previous page)

4. Turn the longer cutting edge of end mill to be parallel to the Slot No.1 of the clamping nut. (Fig. 7-3)

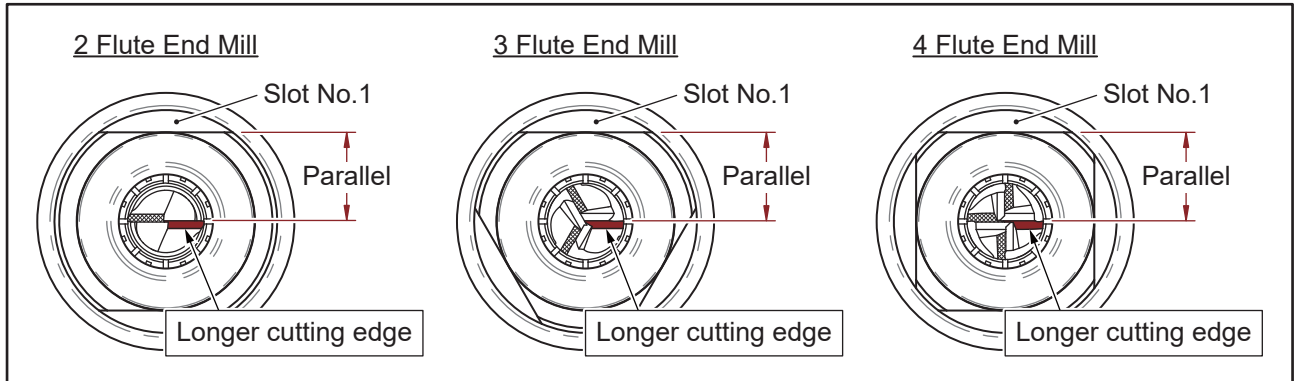

Fig. 7-3

- ✘ If the end mill is too short, the extension rod in the accessory is available for use. Choose the proper extension rod according to the end mill's shank diameter. Insert end mill's shank into the extension rod, and use 2 mm hexagon wrench to tighten the side screw of the extension rod to secure the end mill. (Fig. 7-4)

- ✘ When assembling with the chuck set, put it in from the rear of the chuck set. (Fig. 7-5)

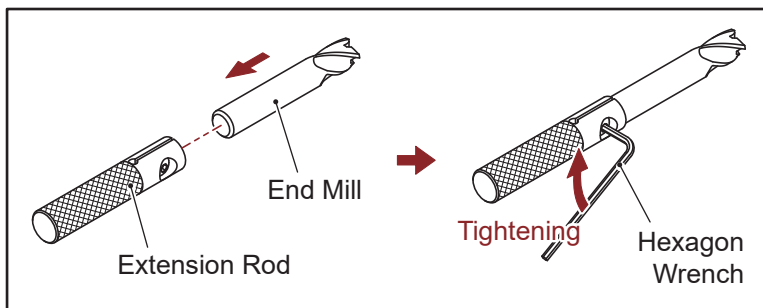

Fig. 7-4

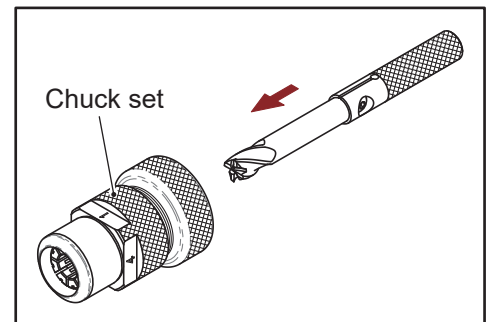

Fig. 7-5

VIII. The use of the Positioning Shelf

1. Preset the scale of the positioning shelf.

- Right Positioning Shelf : $\Phi 3.0 \text{ mm} - \Phi 12.0 \text{ mm}$ (Fig. 8-1)

- ① Turn it by clockwise to the end.
- ② Turn it by counterclockwise at "0".

- Left Positioning Shelf : $\Phi 12.1 \text{ mm} - \Phi 16.0 \text{ mm}$ (Fig. 8-2)

- ① Turn it by clockwise to the end.
- ② Turn it by counterclockwise at "10".

2. Adjust the scale according to end mill's material.

- Adjustment for carbide material end mill :

Adjust according to end mill's cutting diameter.

Eg: 10.0 mm end mill, set at 10.

- Adjustment for HSS material end mill :

Decrease 1-3 scales according to end mill's cutting diameter.

Eg: 8.0 mm end mill, set at 5-7.

3. End mill positioning (Fig. 8-3) :

- ① Align Slot No.1 of the clamping nut to the pin on the positioning shelf, insert the chuck set into the positioning shelf and fit them with no gaps, then turn the chuck set clockwise until it stops by the pin.
- ② Push the end mill to the end and slowly turn it clockwise until the end mill's longer cutting edge stops by the position block.
- ③ Turn the collet holder clockwise and tighten the chuck set to secure end mill.

4. Gently turn the chuck set counterclockwise and take it out, make sure the end mill's longer cutting edge is parallel to the Slot No.1 of clamping nut (See Fig. 7-3).

- ✘ If it is not parallel, adjust the scale (Fig. 8-4) and reposition end mill.

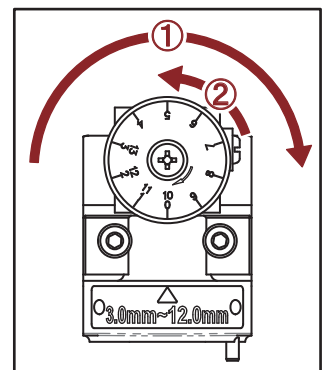

Fig. 8-1

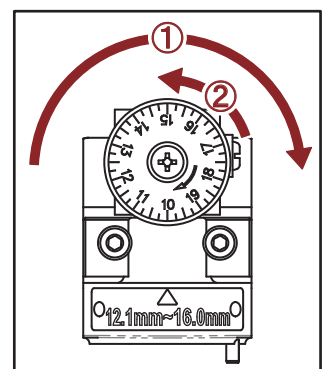

Fig. 8-2

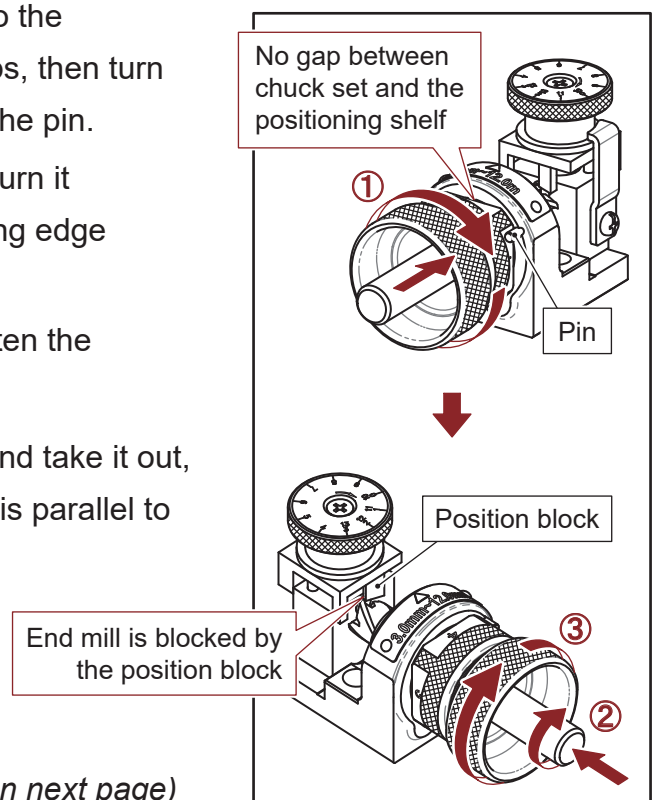

Fig. 8-3

(continued on next page)

(continued from previous page)

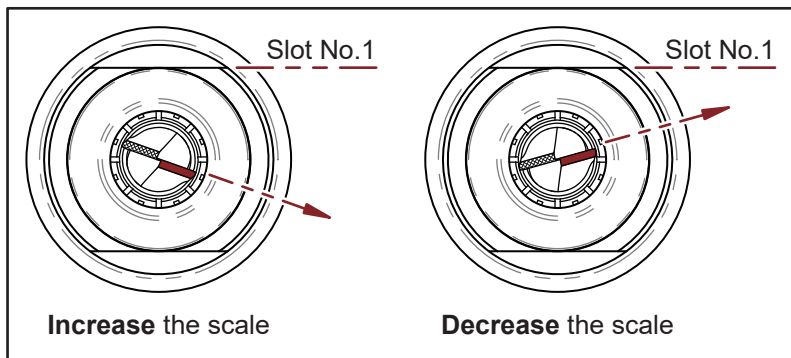

Fig. 8-4

※ Make sure the positioning result is correct before starting the grinding procedure.

IX. The use of the Cutting Face Adjustment Device

This device is to adjust the width of the cutting face. (Fig. 9-1)

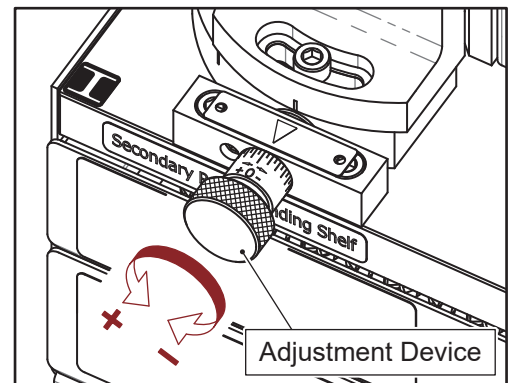
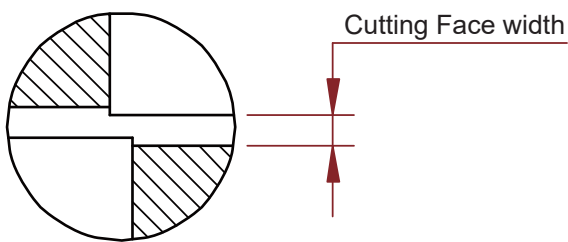

Fig. 9-1

1. Please turn it to “-” direction to the end then set to “0”.
2. Turn to “+” direction to decrease the cutting face width.
Turn to “-” direction to increase the cutting face width.

X. 2 Flute End Mill Grinding Preparations

1. Secondary Relief Grinding Shelf (I) (Fig. 10-1)

- ① Move the adjustable pin on the Shelf (I) from the bottom to top.
- ② Adjust the cutting face adjustment device to “0”, after finishing the whole sharpening procedure, then adjust this device according to your needs. (See chapter “IX. The use of the Cutting Face Adjustment Device”)

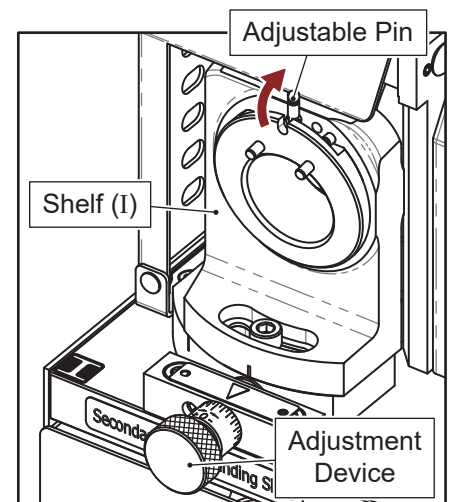

Fig. 10-1

2. Cutting Face Grinding Shelf (III) (Fig. 10-2)

- ① Adjust the Shelf (III) to 3° .
 - ② Insert 2 Flute Cutting Face Bushing into the Shelf (III), align No.1 of the bushing to the pin on the shelf, then insert it to the end.
- ✘ The ● green mark of the bushing should align to the ● green mark on the shelf when inserting the bushing.

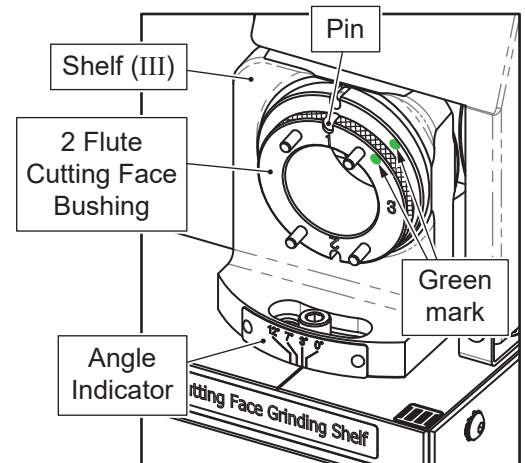

Fig. 10-2

XI. 2 Flute End Mill Grinding Process

Grinding procedure: I, III, IIII

Turn the power switch on and wait about 10 seconds until the motor rotation is stable.

✘ Do not hold the end mill shank while grinding, it may affect the grinding accuracy.

1. 2 Flute Secondary Relief Grinding (I) (Fig. 11-1)

Insert the chuck set into the Shelf (I), align Slot No.1 of clamping nut to the two pins on the shelf, push the chuck set gently and turn it clockwise and counter-clockwise until the grinding noise stops. Turn the chuck set to grind the Slot No.2 in the same way.

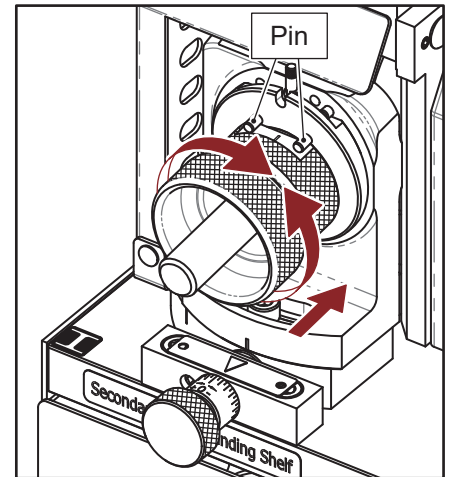

Fig. 11-1

2. 2 Flute Cutting Face Grinding (III) (Fig. 11-2)

① Insert the chuck set into the bushing on the Shelf (III), align Slot No.1 to the two pins where marked as No.1, push the chuck set gently until the grinding noise stops.

② Take the chuck set out and turn the bushing to No.2, align No.2 to the pin on the shelf, then insert it to the end.

③ Insert the chuck set into the bushing, align Slot No.2 to the two pins where marked as No.2, push the chuck set gently until the grinding noise stops.

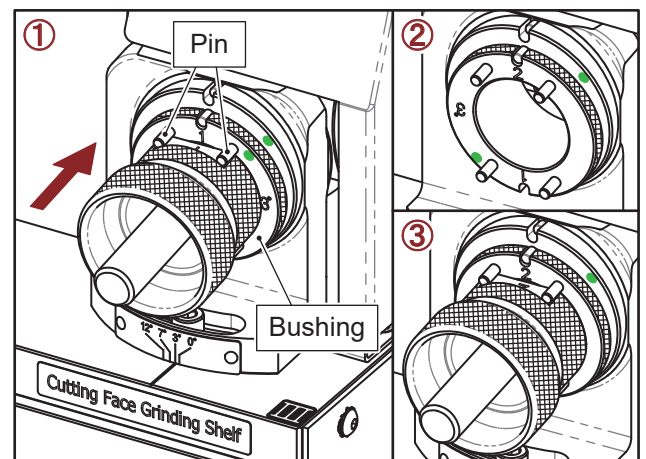

Fig. 11-2

3. 2 Flute End Gash Grinding (IIII) (Fig. 11-3)

Insert the chuck set into the Shelf (IIII), align Slot No.1 to the two pins on the shelf, push the chuck set gently until the grinding noise stops. Turn the chuck set to grind the Slot No.2 in the same way.

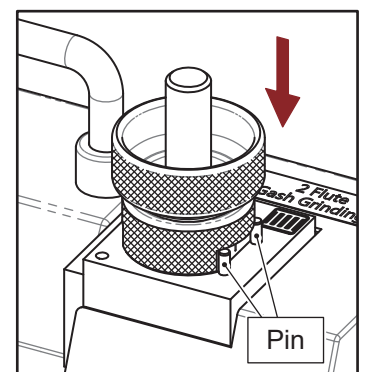

Fig. 11-3

XII. 3 Flute End Mill Grinding Preparations

1. Secondary Relief Grinding Shelf (I) (Fig. 12-1)

- ① Move the adjustable pin on the Shelf (I) from the bottom to top.
- ② Adjust the cutting face adjustment device to “0”, after finishing the whole sharpening procedure, then adjust this device according to your needs. (See chapter “IX. The use of the Cutting Face Adjustment Device”)

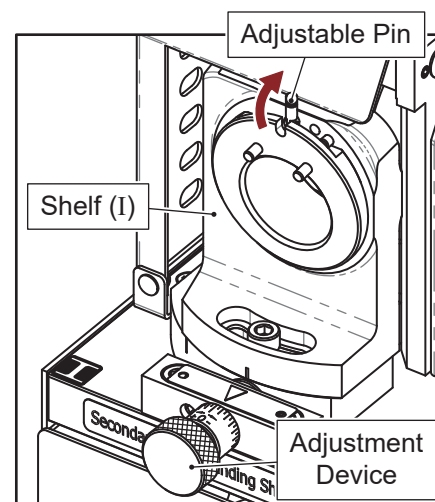

Fig. 12-1

2. End Gash Grinding Shelf (II) (Fig. 12-2)

Insert 3 & 4 Flute End Gash Bushing into the Shelf (II), align No.(I·II) of the bushing to the pin on the shelf, then insert it to the end.

- ✘ The ● pink mark of the bushing should align to the ● pink mark on the shelf when inserting the bushing.

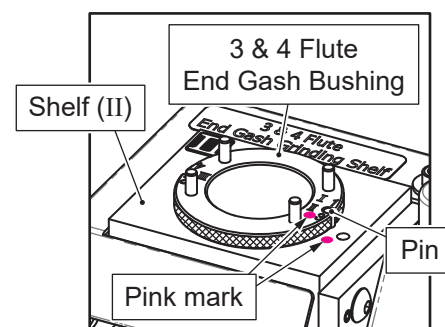

Fig. 12-2

3. Cutting Face Grinding Shelf (III) (Fig. 12-3)

- ① Adjust the Shelf (III) to 3°.
- ② Insert 3 Flute Cutting Face Bushing into the Shelf (III), align No.1 of the bushing to the pin on the shelf, then insert it to the end.

- ✘ The ● green mark of the bushing should align to the ● green mark on the shelf when inserting the bushing.

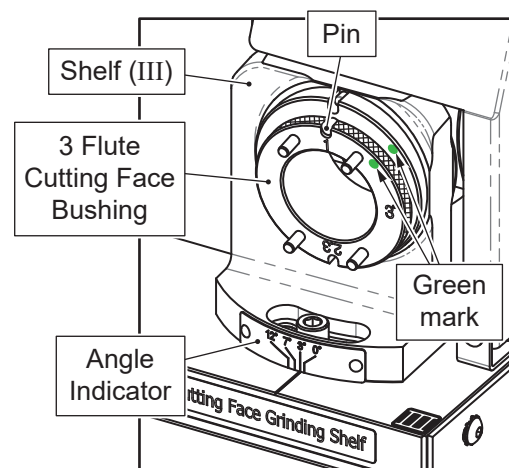

Fig. 12-3

XIII. 3 Flute End Mill Grinding Process

Grinding procedure: I, II, III

Turn the power switch on and wait about 10 seconds until the motor rotation is stable.

※ Do not hold the end mill shank while grinding, it may affect the grinding accuracy.

1. 3 Flute Secondary Relief Grinding (I) (Fig. 13-1)

Insert the chuck set into the Shelf (I), align Slot No.1 of clamping nut to the two pins on the shelf, push the chuck set gently and turn it clockwise and counterclockwise until the grinding noise stops. Turn the chuck set to grind the Slot No.2 and Slot No.3 in the same way.

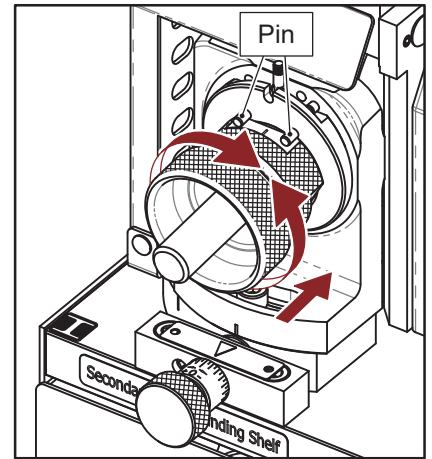

Fig. 13-1

2. 3 Flute End Gash Grinding (II) (Fig. 13-2)

① Insert the chuck set into the bushing on the Shelf (II), align Slot No.1 to the two pins where marked as No.(I·II), push the chuck set gently until the grinding noise stops. Turn the chuck set to grind the Slot No.2 in the same way.

② Take the chuck set out, turn the bushing to No.(III), align No.(III) to the pin on the shelf, then insert it to the end.

③ Insert the chuck set into the bushing, align Slot No.3 to the two pins where marked as No.(III), push the chuck set gently until the grinding noise stops.

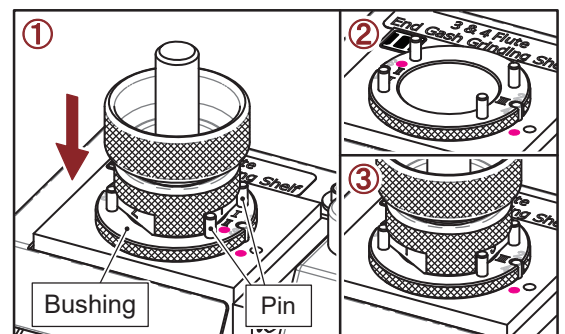

Fig. 13-2

3. 3 Flute Cutting Face Grinding (III) (Fig. 13-3)

① Insert the chuck set into the bushing on the Shelf (III), align Slot No.1 to the two pins where marked as No.1, push the chuck set gently until the grinding noise stops.

② Take the chuck set out, turn the bushing to No.(2·3), align No.(2·3) to the pin on the shelf, then insert it to the end.

③ Insert the chuck set into the bushing, align Slot No.2 to the two pins where marked as No.(2·3), push the chuck set gently until the grinding noise stops. Turn the chuck set to grind the Slot No.3 in the same way.

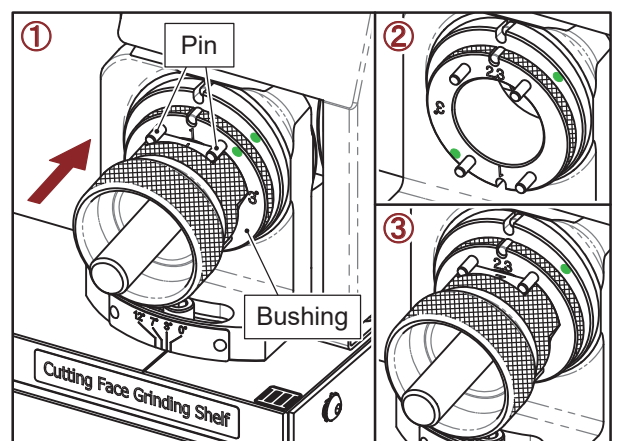

Fig. 13-3

XIV. 4 Flute End Mill Grinding Preparations

1. Secondary Relief Grinding Shelf (I) (Fig. 14-1)

- ① Move the adjustable pin on the Shelf (I) from the top to bottom.
- ② Adjust the cutting face adjustment device to “0”, after finishing the whole sharpening procedure, then adjust this device according to your needs. (See chapter “IX. The use of the Cutting Face Adjustment Device”)

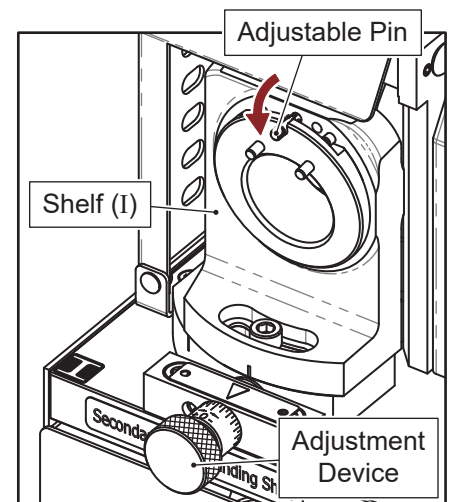

Fig. 14-1

2. End Gash Grinding Shelf (II) (Fig. 14-2)

Insert 3 & 4 Flute End Gash Bushing into the Shelf (II), align No.(1·3) of the bushing to the pin on the shelf, then insert it to the end.

- ✘ The ● pink mark of the bushing should align to the ● pink mark on the shelf when inserting the bushing.

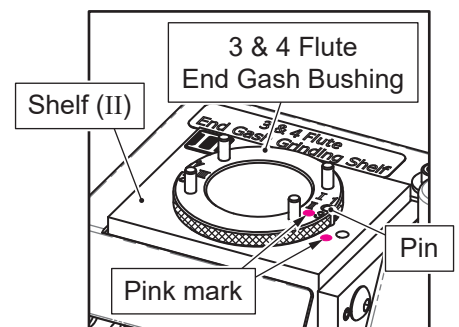

Fig. 14-2

3. Cutting Face Grinding Shelf (III) (Fig. 14-3)

- For grinding the diameter from $\Phi 3.0 - 8.0$ mm.
 - ① Adjust the Shelf (III) to 12° .
 - ② Choose 4 Flute Cutting Face Bushing (12 deg).
- For grinding the diameter from $\Phi 8.1 - 16.0$ mm.
 - ① Adjust the Shelf (III) to 7° .
 - ② Choose 4 Flute Cutting Face Bushing (7 deg).

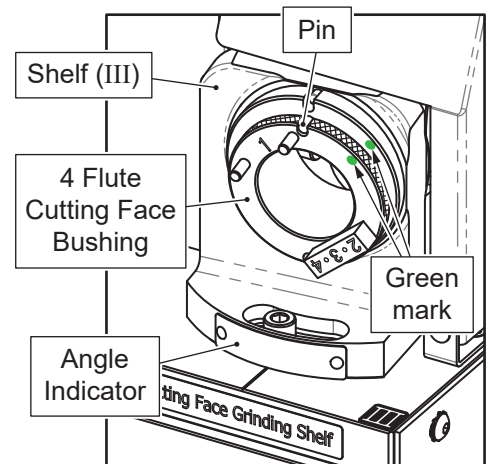

Fig. 14-3

Insert the proper bushing into the Shelf (III), align No.1 of the bushing to the pin on the shelf, then insert it to the end.

- ✘ The ● green mark of the bushing should align to the ● green mark on the shelf when inserting the bushing.

XV. 4 Flute End Mill Grinding Process

Grinding procedure: I, II, III

Turn the power switch on and wait about 10 seconds until the motor rotation is stable.

✘ Do not hold the end mill shank while grinding, it may affect the grinding accuracy.

1. 4 Flute Secondary Relief Grinding (I) (Fig. 15-1)

Insert the chuck set into the Shelf (I), align Slot No.1 of clamping nut to the two pins on the shelf, push the chuck set gently until the grinding noise stops. Turn the chuck set to grind the Slot No.2, Slot No.3 and Slot No.4 in the same way.

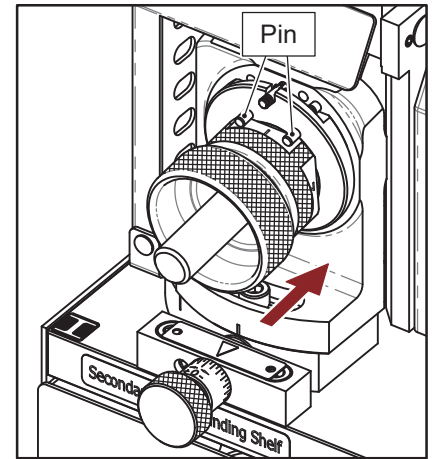

Fig. 15-1

2. 4 Flute End Gash Grinding (II) (Fig. 15-2)

① Insert the chuck set into the bushing on the Shelf (II), align Slot No.1 to the two pins where marked as No.(1·3), push the chuck set gently until the grinding noise stops. Turn the chuck set to grind the Slot No.3 in the same way, then take the chuck set out.

② Turn the bushing to No.(2·4), align No.(2·4) to the pin on the shelf, then insert it to the end.

③ Insert the chuck set into the bushing, align Slot No.2 to the two pins where marked as No.(2·4), push the chuck set gently until the grinding noise stops. Turn the chuck set to grind the Slot No.4 in the same way.

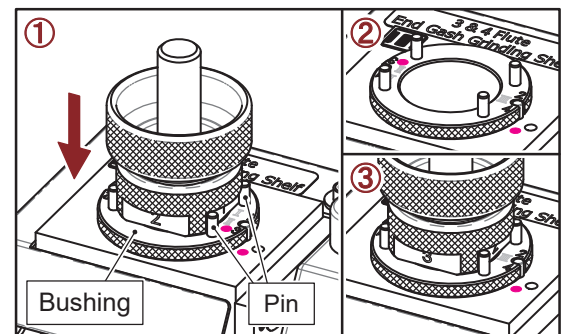

Fig. 15-2

3. 4 Flute Cutting Face Grinding (III) (Fig. 15-3)

① Insert the chuck set into the bushing on the Shelf (III), align Slot No.1 to the two pins where marked as No.1, push the chuck set gently until the grinding noise stops, then take the chuck set out.

② Turn the bushing to No.(2·3·4), align No.(2·3·4) to the pin on the shelf, then insert it to the end.

③ Insert the chuck set into the bushing, align Slot No.2 to the flat key where marked as No.(2·3·4), push the chuck set gently until the grinding noise stops. Turn the chuck set to grind the Slot No.3 and Slot No.4 in the same way.

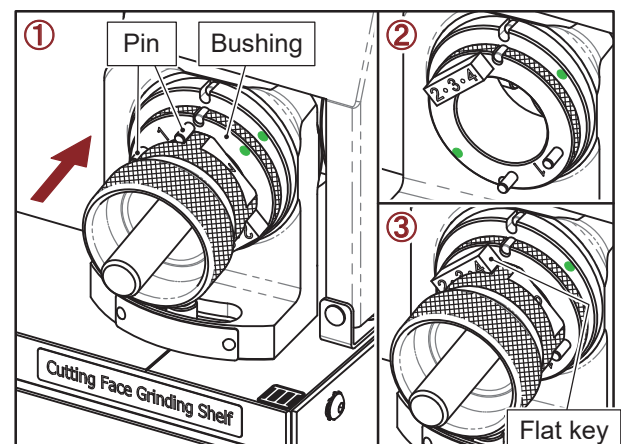

Fig. 15-3

XVI. Machine Maintenance and Clean

1. Replacement of Grinding Wheel

✘ Do not exchange our grinding wheel with other grinding wheel from other supplier!

① Unplug the power cord and make sure the power is off.

② Confirm the screw direction on the grinding wheel cover before changing the grinding wheel. (Fig. 16-1)

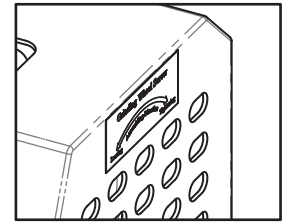

Fig. 16-1

③ Loosen the screw from the grinding wheel cover to open the cover. (Fig. 16-2)

④ Loosen the screw from the grinding wheel to take off the grinding wheel. (Fig. 16-3)

⑤ Use clean cloth to clean the flange and the contact surface of the grinding wheel.

⑥ Replace the new grinding wheel and fasten the screw. (Fig. 16-3)

✘ Tighten the wheel screw until the fan can't be moved separately, do not over tighten.

⑦ Close the grinding wheel cover and secure with screw.

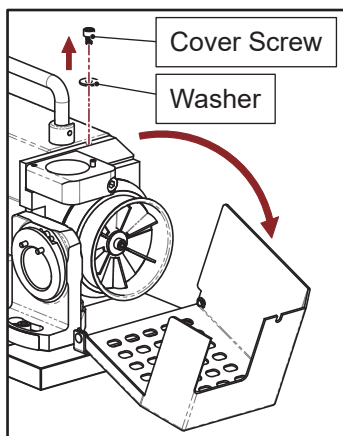

Fig. 16-2

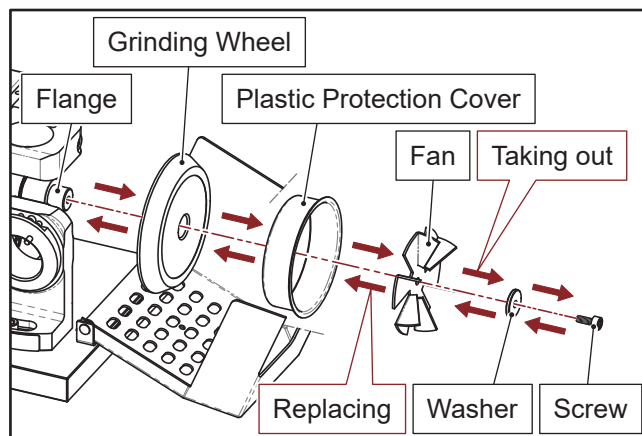

Fig. 16-3

2. Cleaning

① Unplug the power cord and make sure the power is off.

② Disassemble the chuck set after use.

③ Use the air press gun to clean the scraps and dust out of all grinding shelves and all the accessories. (Fig. 16-4, Fig. 16-5)

✘ Please wear protection glass while using the air press gun.

④ Use clean cloth to clean each contact port and all the accessories, then put them back in order.

(Fig. 16-4, Fig. 16-5)

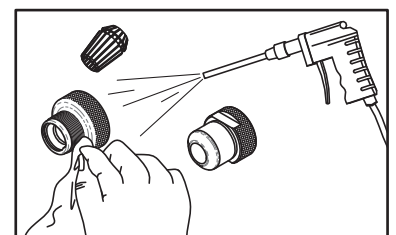

Fig. 16-4

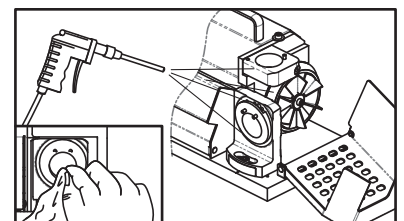

Fig. 16-5

XVII. Troubleshooting

1. End mill is positioned but incorrect result.
 - Check the end mill's cutting edge is clean without scraps / iron ash.
 - The outer corner of the end mill's cutting edge must touch the tip of the alignment block.
 - Check the contact surface of positioning shelf is clean without scraps.
 - Check the position block, if it is damaged, please contact your agent for replacement.
 - Check the position block is clean without scraps / iron ash.
2. Positioning result is correct but failed accuracy after grinding.
 - ✘ If encountered any of the following problems, please reposition the end mill and regrind.
 - ① Problem with grinding shelf :
 - Check the angle of the cutting face grinding shelf (III).
 - ✘ After adjusting the angle, must fasten the set screw of the grinding shelf.
 - Check the contact surface of grinding shelf is clean without scraps / iron ash.
 - ② Problem with end mill :
 - Check the peripheral cutting edge, if it is damaged should be cut off.
 - If end mill is deformed or has unequal flute, may affects the grinding accuracy.
 - ③ Problem with accessories :
 - Check the cleanliness of chuck set (collet / collet holder / clamping nuts).
 - Check the contact surface of bushing is clean without scraps / iron ash.
 - Check the grinding wheel, if it is damaged, please contact your agent for replacement.
 - While changing grinding wheel, the flange and the center hole of grinding wheel should be kept clean.
 - ④ Problem with end mill grinding :
 - Do not apply too much pressure to grinding shelf.
 - Make sure each cutting face of the end mill must be sharpened completely.
3. In case of product or component damage, switch off the machine and disconnect the power cord. Contact your local authorized supplier for repair or replacement.

