



GSC Grinding Machine **For Drill and End Mill series**

Super Simple
Super Easy
Super Fast
Super Efficiency



GSC innovates for making you work happier.



Drill Bit Grinder

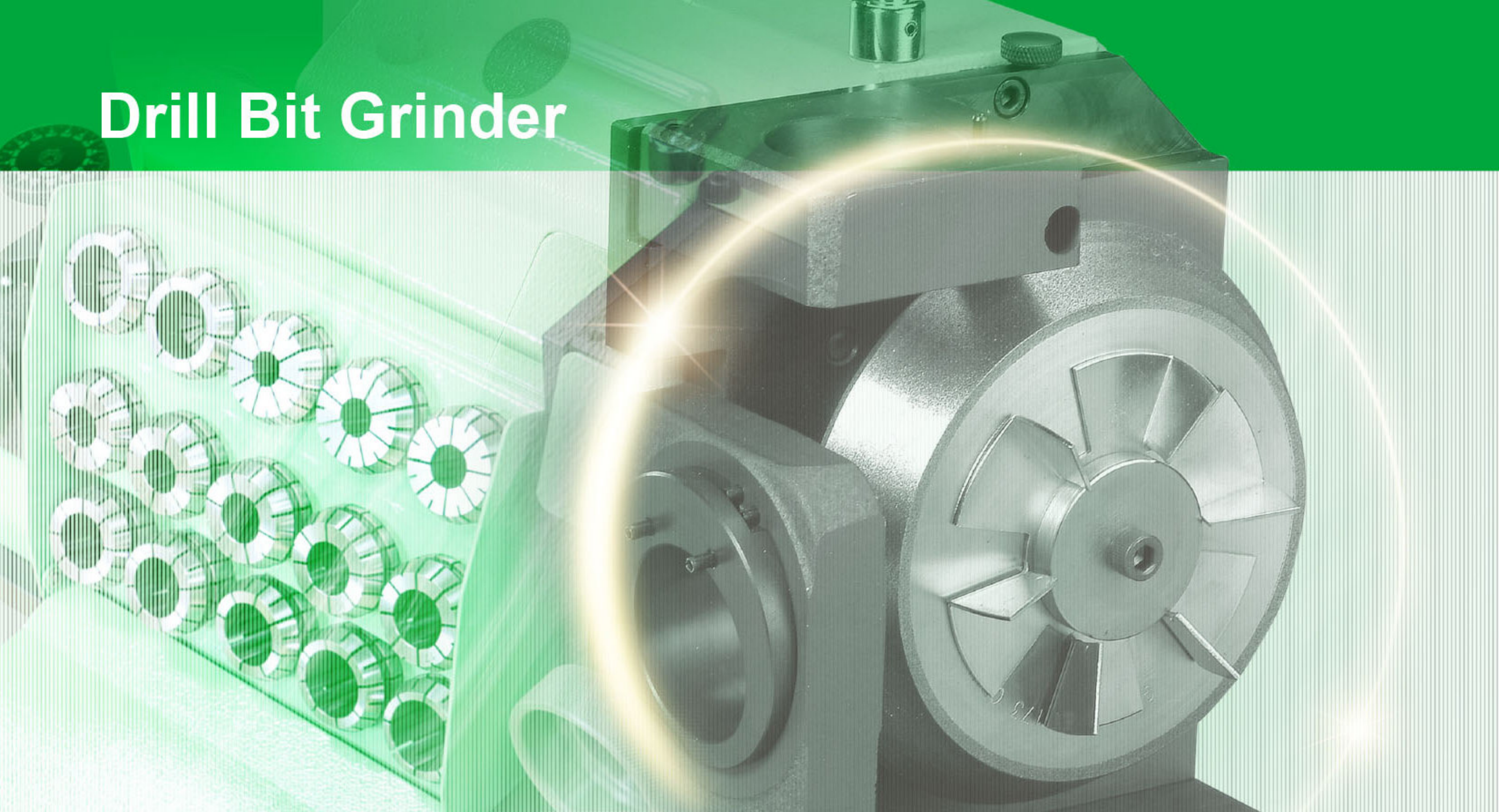

GS-1 Twist Drill Resharpener



High Quality Grinding Slip



For Φ 2mm - 13mm Twist Drill Resharpener
Adjustable Point Angle 90° - 140°
CBN#200 For HSS /SD#200 For Carbide (Opt.)

GS-20 Twist Drill Resharpener



Twist drill bits



Deep-slot drill bits



Coating drill bits

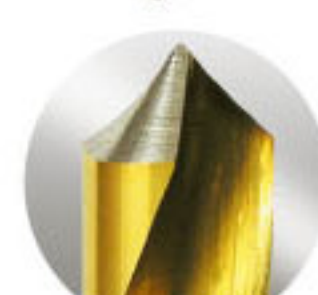

NC spotting

For Φ 2mm - 20mm Twist Drill Resharpener
Adjustable Point Angle 90° - 140°
CBN#200 For HSS /SD#200 For Carbide (Opt.)

GS-21 Twist Drill Resharpener



Twist drill bits



Deep-slot drill bits



Coating drill bits

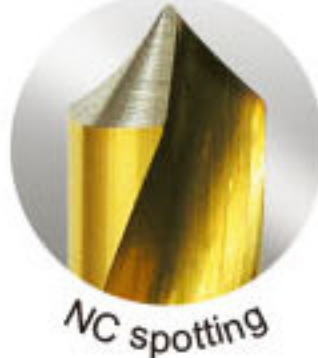

NC spotting

For Φ 12mm - 26mm Twist Drill Resharpener
Adjustable Point Angle 90° - 140°
CBN#200 For HSS /SD#200 For Carbide (Opt.)

GS-34 Twist Drill Resharpener



Twist drill bits



Deep-slot drill bits



Coating drill bits

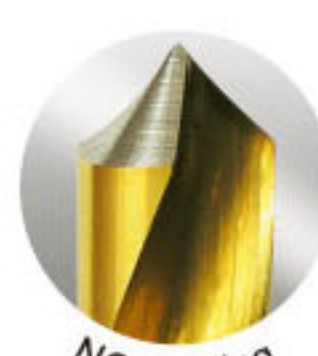

NC spotting

For Φ 12mm - 34mm Twist Drill Resharpener
Adjustable Point Angle 90° - 140°
CBN#200 For HSS /SD#200 For Carbide (Opt.)

GS-35 Twist Drill Resharpener



For $\Phi 2\text{mm} - 34\text{mm}$ Twist Drill Resharpener
 Adjustable Point Angle $90^\circ - 140^\circ$
 CBN#200 For HSS /SD#200 For Carbide (Opt.)
 Collets For Different Shank (Opt.)

GS-52 Twist Drill Resharpener



© Collets: $\Phi 35\text{mm} - 52\text{mm}$ (Optional)
 Wooden box & Plastic box (Optional)



For $\Phi 34.1\text{mm} - 52\text{mm}$ Twist Drill Resharpener
 Adjustable Point Angle $118^\circ - 140^\circ$
 CBN#100 For HSS /SD#100 For Carbide (Opt.)

Cutting-Off Machine



GS-13 Cutting-Off Machine



Dry Cooling



Optional Grinding Wheel Application for GS-13

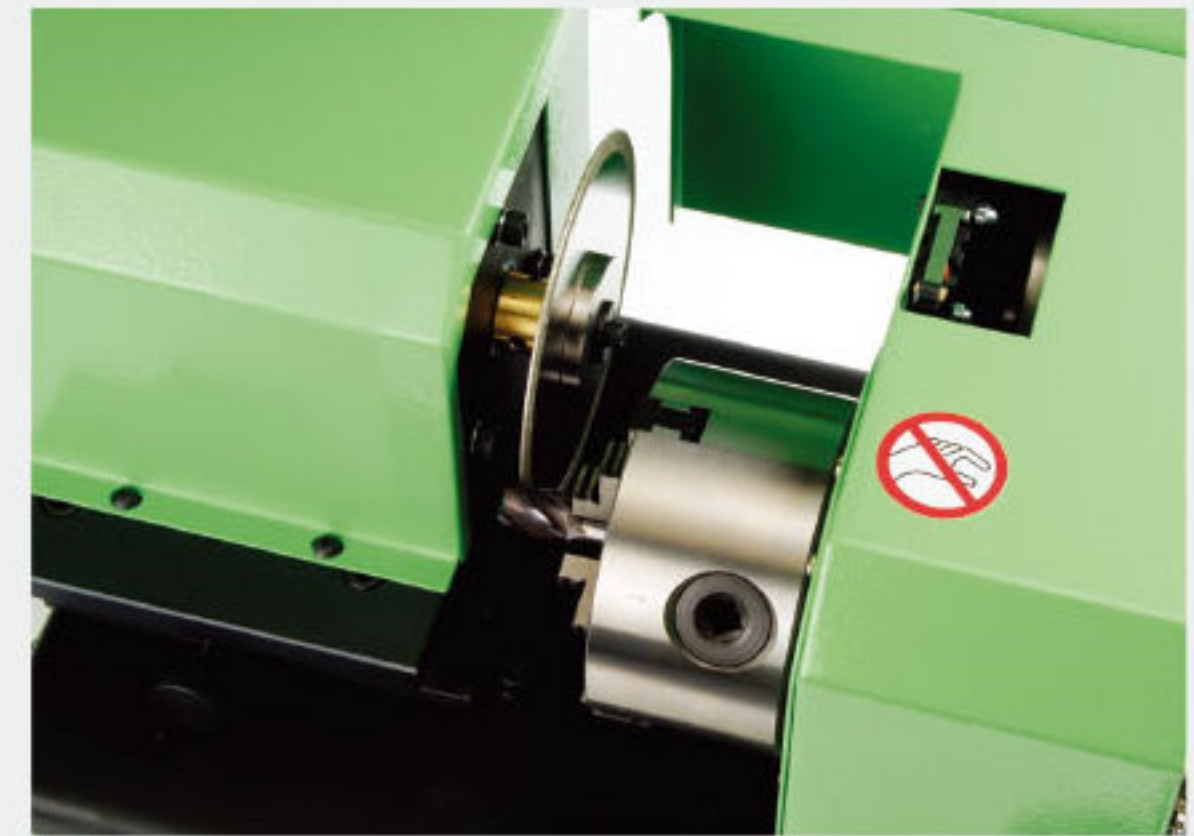

Carbide end mill cutting efficiency on GS-13

- Φ 10mm 4 flute carbide end mill is cut by SD#100 cutting disc takes 55 seconds.
- Φ 16mm 4 flute carbide end mill is cut by SD#100 cutting disc takes 100 seconds.

GS-13+ Cutting-Off Machine



Workpiece can be rotated 0 ~ 20 degrees

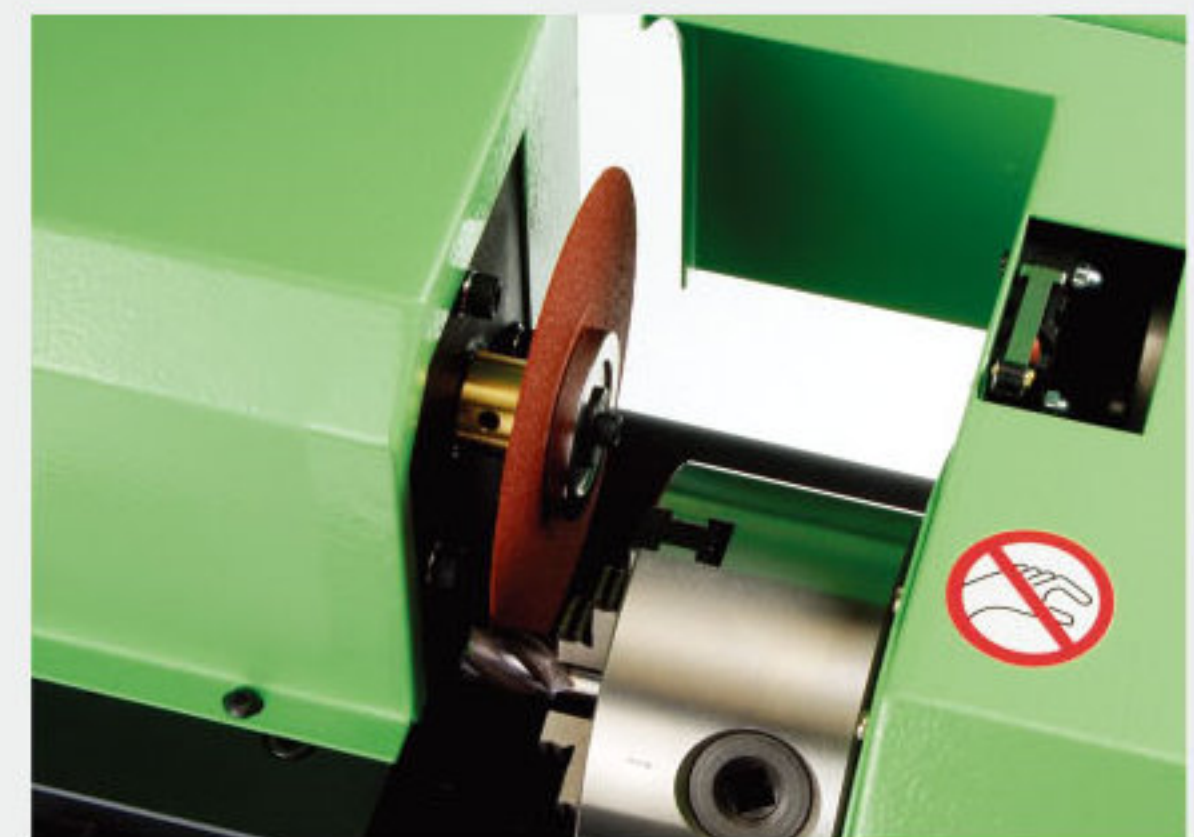

HSS end mill cutting efficiency on GS-13

- Φ 10mm 4 flute HSS end mill is cut by E60WA cutting disc takes 60 seconds.
- Φ 16mm 4 flute HSS end mill is cut by E60WA cutting disc takes 110 seconds.

GS-33 Cutting-Off Machine



1. Convenient Design
X, Y axis workable professional structure enhanced high-performance cutting accuracy.
2. Cutting Capacity
For GS-13
Cutting diameter: Φ 3 ~ 16mm;
Cutting length of work-piece end: 15mmL/max
For GS-33
Cutting diameter: Φ 16~32mm;
Cutting length of work-piece end: 20mmL/max
3. Patented Radius cutting by Dual-motor driver
The hardened treatment steel is controlled well in virtue of natural dissipation characteristic, cutting time is greatly shortened as the work-piece is simultaneously rotated while cutting.
4. Quick-Work-Changing System
The work-piece is quickly exchanged with prime quality 3-Jaw chuck system.
5. Cooling System
Dry cooling is able to connect with various pressurized air and vacuum cleaner achieved perfect cooling effect.
6. Cutting Disc
SD#100 for carbide, CBN#100 for HSS
7. Optional Grinding Wheel For GS-13
SD#200 thickness 5mm, 10mm for carbide, CBN#200 thickness 5mm, 10mm for HSS.

End Mill Grinder

GS-6 End Mill Resharpener



For Φ 3mm - 12mm End Mill Resharpener
 Adjustable Cutting Face Angle
 Adjustable Width of Cutting Face
 SD#200 For Carbide / CBN#200 For HSS (Opt.)

GS-6 Standard accessories



GS-26 End Mill Resharpener



For Φ 10.0mm - 26mm End Mill Resharpener
 Adjustable Cutting Face Angle
 Adjustable Width of Cutting Face
 SD#200 For Carbide / CBN#200 For HSS(Opt.)

GS-26 Standard accessories



GS-62 End Mill Resharpener



For $\Phi 3\text{mm} - 12\text{mm}$ End Mill Resharpener
 Adjustable Cutting Face Angle
 Adjustable Width of Cutting Face
 SD#200 For Carbide / CBN#200 For HSS (Opt.)



GS-66 End Mill Resharpener



For $\Phi 3\text{mm} - 16\text{mm}$ End Mill Resharpener
 Adjustable Cutting Face Angle
 Adjustable Width of Cutting Face
 SD#200 For Carbide / CBN#200 For HSS (Opt.)



GS-76 End Mill Resharpener



For $\Phi 3\text{mm} - 20\text{mm}$ End Mill Resharpener
 Adjustable Cutting Face Angle
 Adjustable Width of Cutting Face
 SD#200 For Carbide / CBN#200 For HSS (Opt.)



Corner Radius End Mill



GS-65 Corner Radius Of End Mill Resharpener

For $\Phi 4\text{mm} - 12\text{mm} / 13\text{mm} - 16\text{mm}$ (Opt.)
Adjustable Radius R0.5, R1.5/ R1.0, R2.0
SD#200 For Carbide
CBN#200 For HSS (Opt.)
Collets For Different Shank (Opt.)



Corner Radius of End Mill

SG Drill



GS-18 SG High Speed Drill ESS 7572P Resharpener

For $\Phi 3\text{mm} - 13\text{mm}$ SG High Speed Drill Resharpener
Point Angle 135°
CBN#200 For HSS /SD#200 For Carbide (Opt.)

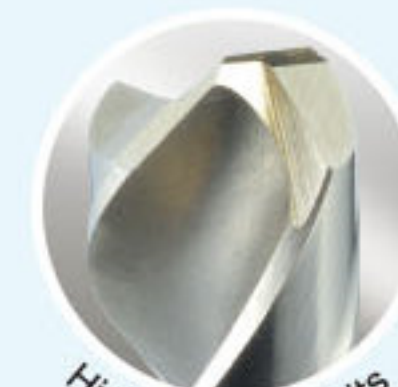

High speed drill bits

GS-19 SG Three Rake Drill ES 7570P Resharpener

For $\Phi 3\text{mm} - 13\text{mm}$ DG Three Rake Drill Resharpener
Point Angle 135°
CBN#200 For HSS /SD#200 For Carbide (Opt.)



DG three rake drill bits

GS-28 SG High Speed Drill ESS 7572P Resharpener

For $\Phi 12\text{mm} - 22\text{mm}$ SG High Speed Drill Resharpener
Point Angle 135°
CBN#200 For HSS /SD#200 For Carbide (Opt.)

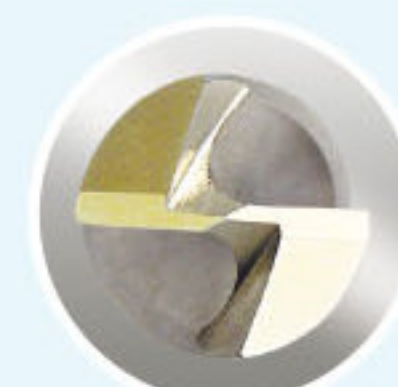

High speed drill bits

Special Drill Bit Grinder



GS-3 Left Hand Twist Drill Resharpener



For Φ 2mm - 13mm Left Hand Twist Drill Resharpener
Adjustable Point Angle 118° - 135°
CBN#200 For HSS /SD#200 For Carbide (Opt.)



GS-5 Sheet Metal Drill Resharpener



For Φ 3mm - 13mm Sheet Metal Drill Resharpener
Adjustable Point Angle 165° - 180°
CBN#200 For HSS /SD#200 For Carbide (Opt.)

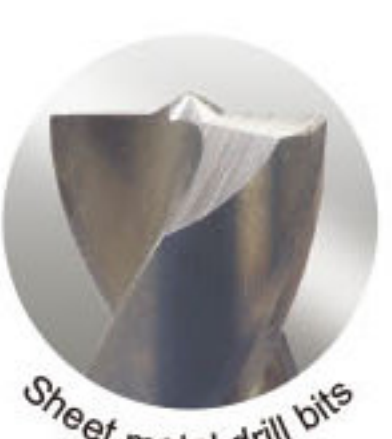

GS-22 Iron Frame Drill Resharpener



For Φ 12mm - 26mm Iron Frame Drill
Adjustable Point Angle 160° - 180°
CBN#200 For HSS /SD#200 For Carbide (Opt.)



GS-32 Iron Frame Drill Resharpener



For Φ 12mm - 34mm Iron Frame Drill
Adjustable Point Angle 160° - 180°
CBN#200 For HSS /SD#200 For Carbide (Opt.)



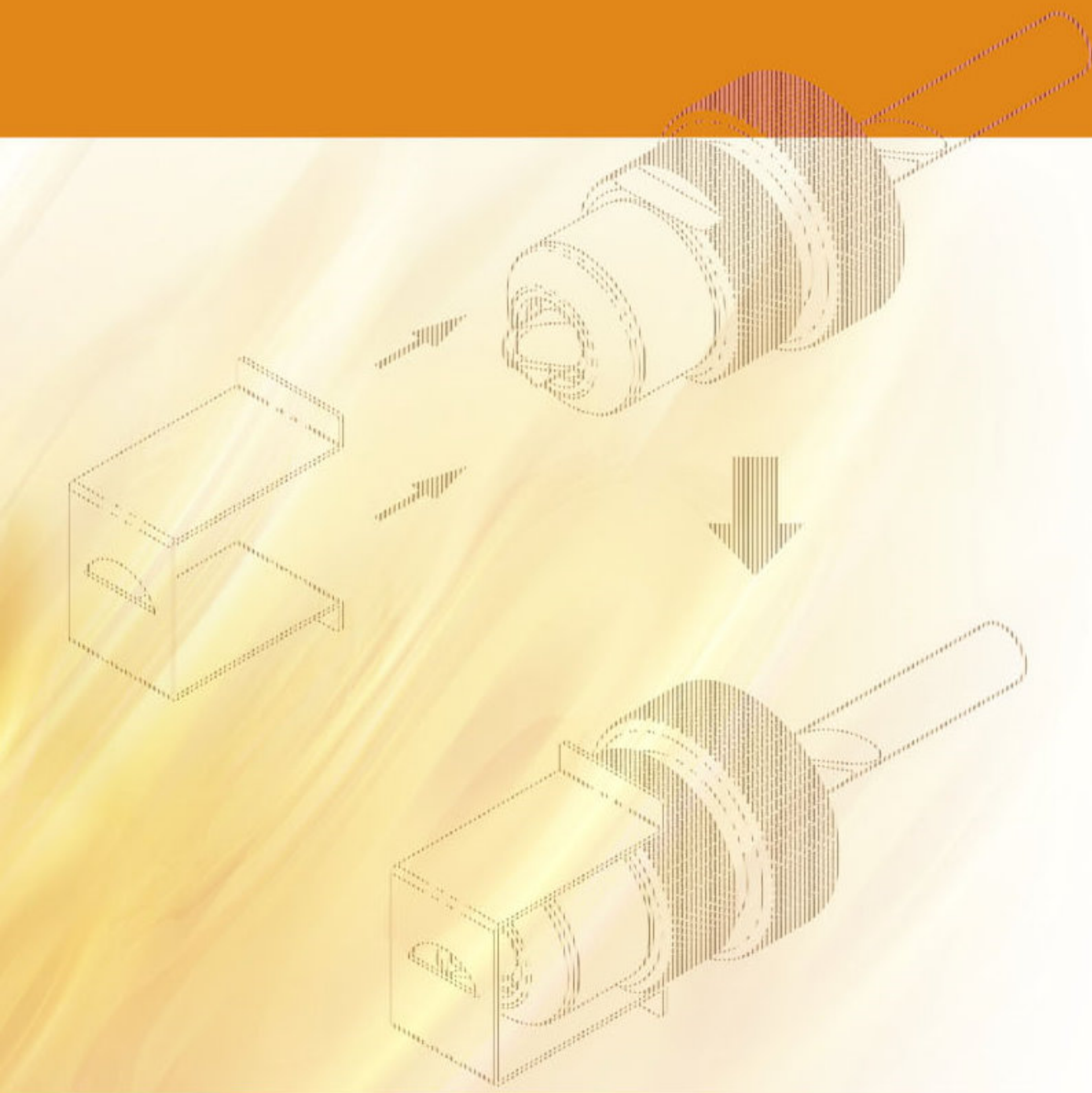

GS-14 Three Flute Drill Resharpener



For Φ 3mm - 13mm Three Flute Drill Resharpener
Adjustable Point Angle 130° - 150°
CBN#200 For HSS /SD#200 For Carbide (Opt.)



Three flute drill bits

GS-15 Three Flute Sheet Metal Drill Resharpener



For Φ 3mm - 13mm Three Flute Sheet Metal Drill Resharpener
Adjustable Point Angle 165° - 180°
CBN#200 For HSS /SD#200 For Carbide (Opt.)



Three flute sheet metal drill bits

GS-16 Woodworking Drill Resharpener



For Φ 3mm - 13mm
Woodworking Drill Resharpener
CBN#200 For HSS /SD#200 For Carbide (Opt.)

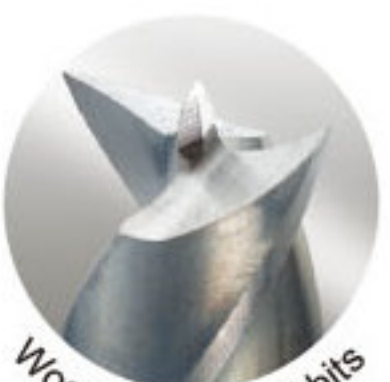

Woodworking drill bits

GS-17 Tungsten Bar Resharpener

Collet Type

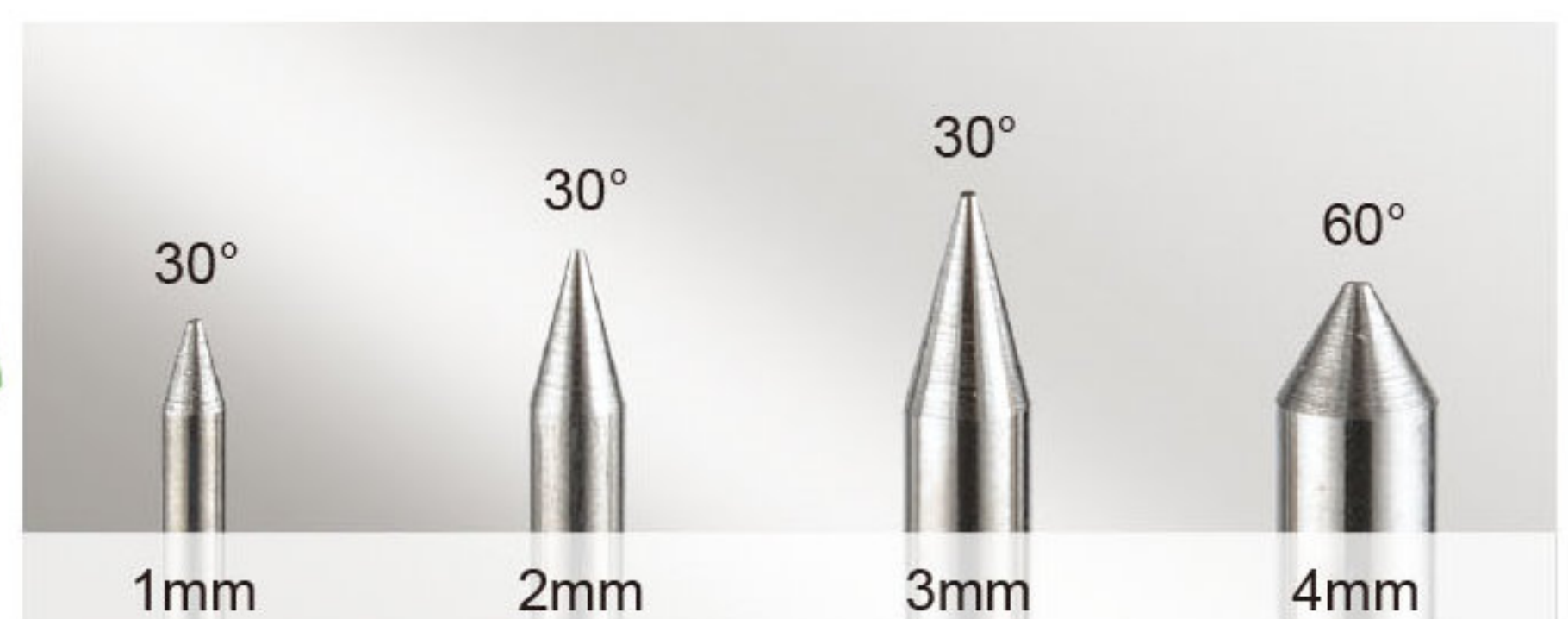
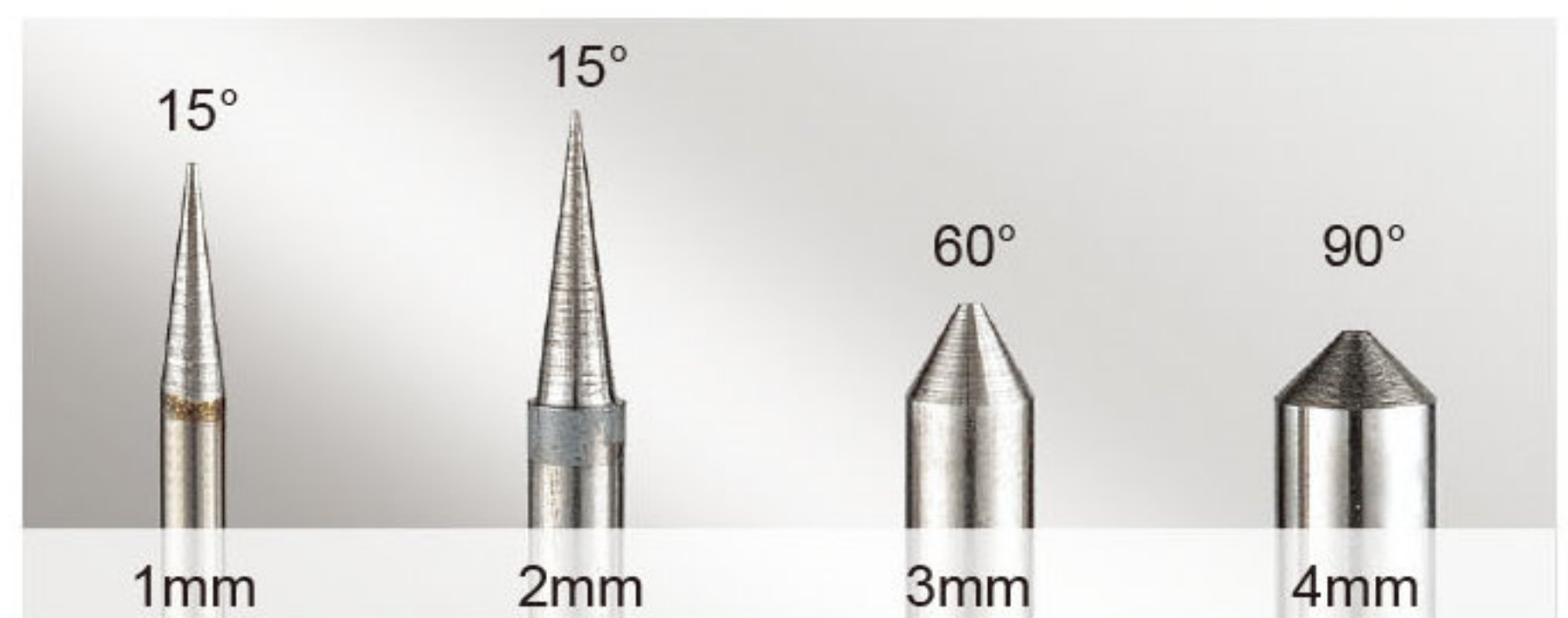

Dual Head Drill Bit Grinder



GS-7 Sheet Metal & Twist Drill Resharpener



For Φ 3mm - 13mm Sheet Metal Drill Resharpener
Adjustable Point Angle 165° - 180°
For Φ 2mm - 13mm Twist Drill Resharpener
Adjustable Point Angle 90° - 140°
CBN#200 For HSS /SD#200 For Carbide (Opt.)



Sheet metal drill bit



Twist drill bits



Deep-slot drill bits



Coating drill bits

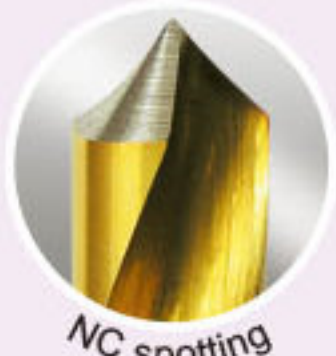

NC spotting

GS-27 Iron Frame Drill & Twist Drill Resharpener



For Φ 12mm - 26mm Iron Frame Drill Resharpener
Adjustable Point Angle 160° - 180°
For Φ 12mm - 26mm Twist Drill Resharpener
Adjustable Point Angle 90° - 140°
CBN#200 For HSS /SD#200 For Carbide (Opt.)



Iron frame drill bit



Twist drill bits



Deep-slot drill bits



Coating drill bits



NC spotting

GS-8 Left Hand Twist Drill & Twist Drill Resharpener



For Φ 2mm - 13mm Left Hand Twist Drill Resharpener
Adjustable Point Angle 118° - 135°
For Φ 2mm - 13mm Twist Drill Resharpener
Adjustable Point Angle 90° - 140°
CBN#200 For HSS /SD#200 For Carbide (Opt.)



Left hand twist drill bit



Twist drill bits



Deep-slot drill bits



Coating drill bits



NC spotting

GS-61 Twist Drill & End Mill Resharpener



For Φ 2mm - 13mm Twist Drill Resharpener
Adjustable Point Angle 90° - 140°
CBN#200 For HSS / SD#200 For Carbide(Opt.)
For Φ 3mm - 12mm End Mill Resharpener
Adjustable Cutting Face Angle and Width
SD#200 For Carbide / CBN#200 For HSS (Opt.)



Twist drill bits



Deep-slot drill bits



Twist drill bits



Deep-slot drill bits



Coating drill bits

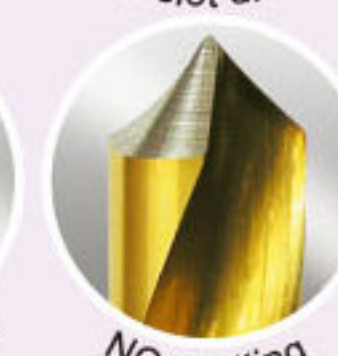

NC spotting

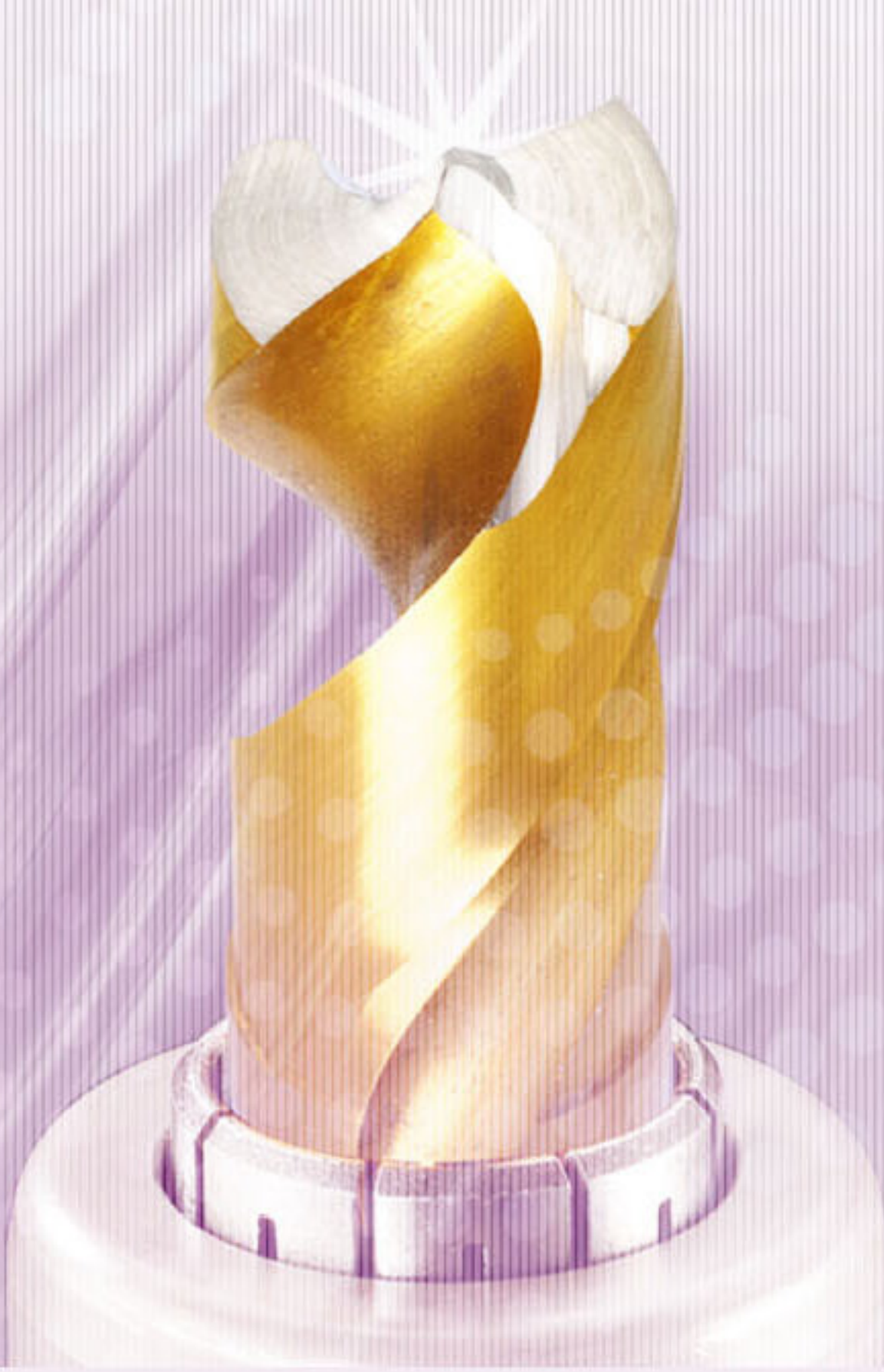

GS-9

SG Three Rake Drill ES 7570P & Twist Drill Resharpener



For Φ 3mm - 13mm SG Three Rake Drill Resharpener
Adjustable Point Angle 118° - 140°
For Φ 2mm - 13mm Twist Drill Resharpener
Adjustable Point Angle 90° - 140°
CBN#200 For HSS /SD#200 For Carbide (Opt.)

GS-29

SG Three Rake Drill ES 7570P & Twist Drill Resharpener



For Φ 12mm - 26mm SG Three Rake Drill Resharpener
Adjustable Point Angle 118° - 140°
For Φ 12mm - 26mm Twist Drill Resharpener
Adjustable Point Angle 90° - 140°
CBN#200 For HSS /SD#200 For Carbide (Opt.)

GS-10

SG High Speed Drill ESS 7572P & Twist Drill Resharpener



For Φ 3mm - 13mm SG High Speed Drill Resharpener
Point Angle 135°
For Φ 2mm - 13mm Twist Drill Resharpener
Adjustable Point Angle 90° - 140°
CBN#200 For HSS /SD#200 For Carbide (Opt.)

GS-12

SG High Speed Drill ESS 7572P & SG Three Rake Drill ES 7570P Resharpener



For Φ 3mm - 13mm SG High Speed Drill Resharpener
Point Angle 135°
For Φ 3mm - 13mm SG Three Rake Drill Resharpener
Point Angle 135°
CBN#200 For HSS /SD#200 For Carbide (Opt.)

Optional accessories



ER20 collets 	ER32 Collets 	ER-16 Collets and Adapter 	ER-20 Collets For Different Shank 	ER-50 Holder Set 	Wooden Box for Collets
CBN#200 Wheels 	SD#200 Wheels 	Point Angle Gauge 	Parallel Alignment Gadget 	Parallel Alignment Gadget 	Portable LED Light
Dust Collector Attachment 	Dust Collector Attachment 	AL-201 	AL-301 	AL-303 	HO-100

Tool box for ER32 Collets (L:450 W:300 H:166mm)	Accessory box	Tool box for ER20 Collets (L:302.7 W:215.8 H:178.7mm)
<p style="text-align: right;">Front</p> <p style="text-align: right;">Back</p> <p style="text-align: center;">The power supply & indicator light Included</p>	<p style="text-align: center;">No accessories (the accessories in the box are for taking pictures)</p> <p style="text-align: center;">The power supply & indicator light Included</p>	<p style="text-align: right;">Front</p> <p style="text-align: right;">Back</p> <p style="text-align: center;">The power supply & indicator light Included</p>



TAIWAN MORE-CASH VILLAGE CORPORATION
 No. 81, Ren Hua Rd., Ta-Li Dist., Taichung City 412, Taiwan R.O.C.
<http://www.gsc-tw.com> e-mail: website@gsc-tw.com
 TEL : (886) 4-2491-0441 FAX : (886) 4-2491-7430

